

# **INSTRUCTION MANUAL**

## **CALIBRATION EXCITER**

### **VE-10**



3-20-41 Higashimotomachi, Kokubunji, Tokyo 185-8533, Japan  
<http://www.rion.co.jp/english/>



## Organization of This Manual

This manual describes the features and operation principles of the Vibration Exciter VE-10. To ensure safety and accuracy, please read this document carefully.

The manual contains the following sections.

### **Outline**

Gives basic information on the unit.

### **Parts and Functions**

Identifies and explains all parts of the unit.

### **Preparations**

Describes how to insert batteries, how to mount vibration pickup and how to select operation mode.

### **Calibration**

Describes how to calibrate a vibration measurement system and how to perform an accelerometer sensitivity check.

### **Specifications**

Lists the technical specifications of the unit.

To conform to the EU requirement of the Directive 2002/96/EC on Waste Electrical and Electronic Equipment, the symbol mark on the right is shown on the instrument.



CE

The product described in this manual is in conformity with the following European standards;

EN61326:1997+A1:1998+A2:2001+A3:2003

# Operating Precautions

- Operate the unit only as described in this manual.
- Do not disassemble or modify the unit.
- In the vicinity of a strong magnetic field (such as produced by magnets, motors, speakers, etc.), measurement results may be affected.
- The calibration exciter in the unit uses a semipermanent magnet. If cassette tapes, floppy disks, watches or similar are placed close to the unit, erasure or faulty operation may result.
- This is a precision device. Protect it from shocks.
- If the specified torque (0.1 to 0.2 N·m) is exceeded when fastening the vibration pickup, the exciter spring may sustain permanent damage.
- In case of malfunction, do not any attempt any repairs. Note the condition of the unit clearly and contact the supplier.

Note
●

Provides advice on how to use the functions of the unit correctly. Be sure to read this information.



# Contents

Operating Precautions .....	iii
Outline .....	1
Parts and Functions .....	2
Preparations .....	3
Loading Battery .....	3
Attaching Vibration Pickup .....	4
Operation Mode .....	9
Calibration .....	10
Calibration of Vibration Measurement System .....	10
Sensitivity Check of Accelerometer .....	11
Specifications .....	12





# Outline

The VE-10 is a portable vibration exciter designed for calibration of vibration pickup, vibration meter, vibration measurement system, etc.

The VE-10 generates a sinusoidal vibration of  $10 \text{ m/s}^2$  (rms) in acceleration,  $10 \text{ mm/s}$  (rms) in velocity,  $10 \mu\text{m}$  (rms) in displacement.

## Block diagram

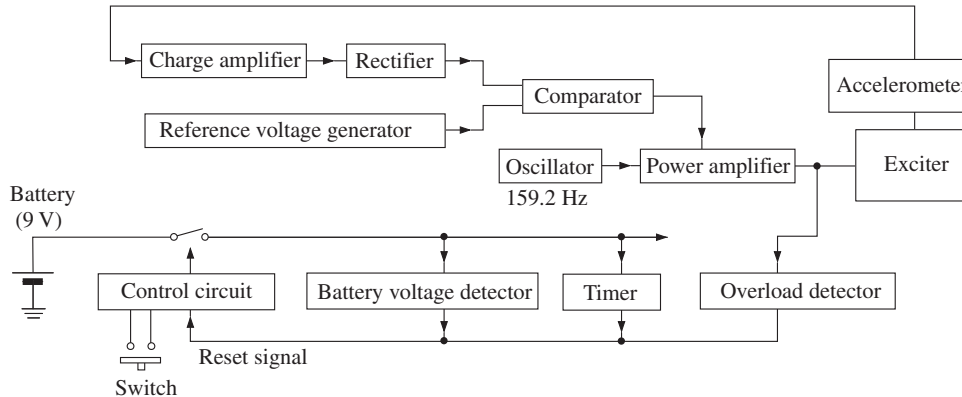

# Parts and Functions

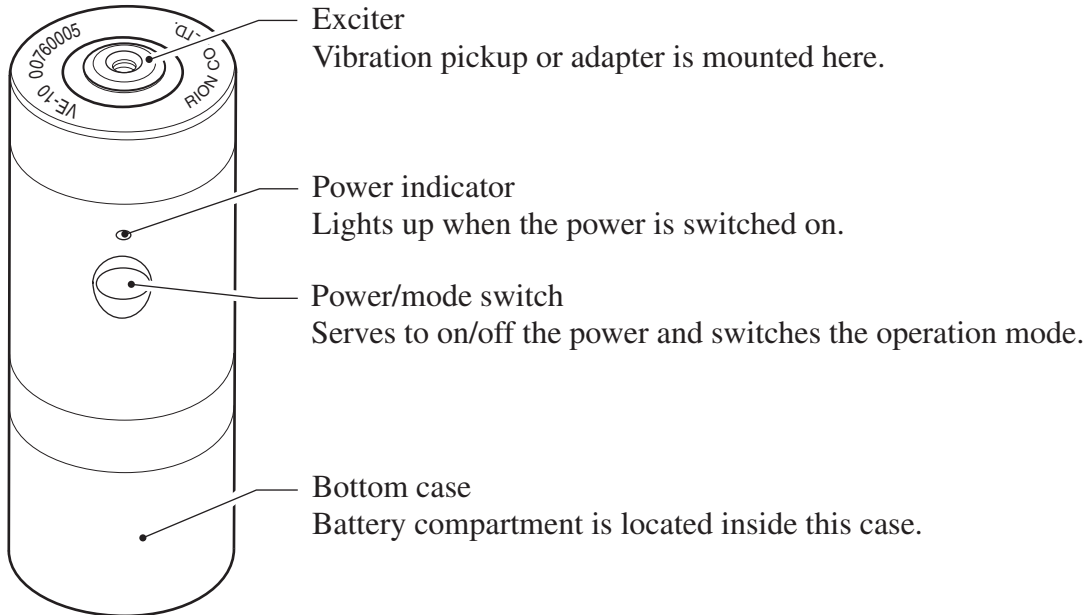

# Preparations

## Loading Battery

1. Turn the bottom case counterclockwise and take it off.
2. With the correct polarity, attach a 6LR61 alkaline battery to the battery connector.
3. Insert the battery in the battery compartment.
4. Screw the bottom case on the unit.

### Note

If continuous mode cannot be activated, or if the unit does not respond when the Power/Mode switch is pressed, replace the battery with fresh one.

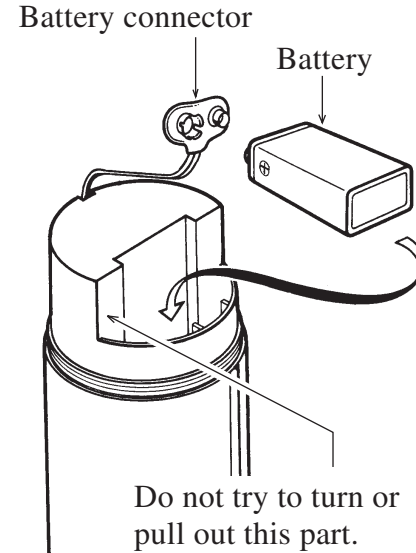

## Attaching Vibration Pickup

Attach the vibration pickup to the VE-10 with one of the following methods, and connect the pickup to the input connector of vibration meter (or vibration level meter) using a low-noise cable.

Torque for fastening the vibration pickup and adapter will be 0.1 to 0.2 N·m; tighten lightly by hand.

### Pickup with M3 screw hole

1. Attach the vibration pickup to the adapter with the M3 screw.
2. Mount the adapter on the exciter of the VE-10.

Note
If the specified torque (0.1 to 0.2 N·m) is exceeded when fastening the vibration pickup, the exciter spring may sustain permanent damage.

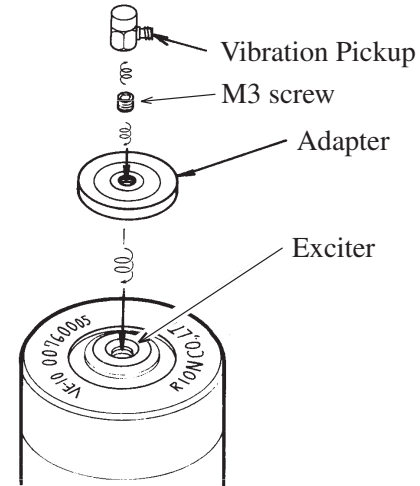
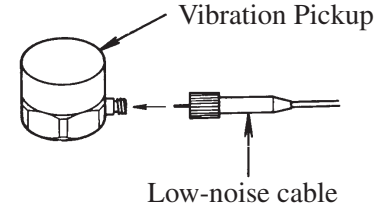

## Vibration Pickup with M6 screw hole

Mount the vibration pickup on the exciter with the M6 screw.

## Vibration Pickup with UNF screw hole

1. Attach the M6-UNF screw (UNF side) to the vibration pickup.
2. Mount the vibration pickup on the exciter using the M6 side of M6-UNF screw.

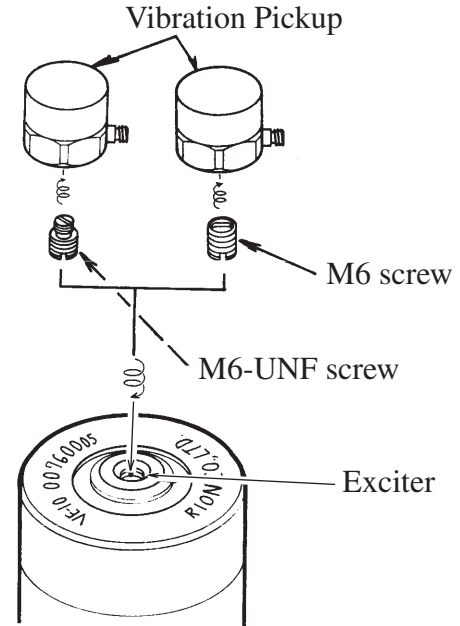

## Vibration Pickup with M6 screw hole (using magnet attachment)

1. Mount the vibration pickup on the magnet attachment with the M6 screw.
2. Mount the adapter on the exciter.
3. Attach the magnet to the adapter.

<b>Note</b>
To remove the magnet, slide it on the adapter.

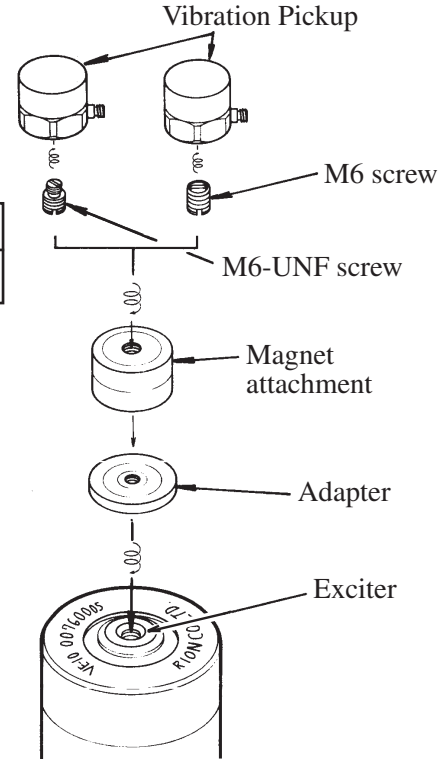

### **Vibration Pickup with UNF screw hole (using magnet attachment)**

1. Attach the M6-UNF screw (UNF side) to the vibration pickup.
2. Mount the vibration pickup on the magnet attachment using the M6 side of M6-UNF screw.
3. Mount the adapter on the exciter.
4. Attach the magnet to the adapter.

### Adhesive mounting type vibration pickup

1. Mount the adapter on the exciter.
2. Attach the vibration pickup to the adapter with both-sided adhesive tape.

Note
When attaching a triaxial type vibration pickup, be careful of the measurement axes (X, Y, Z).

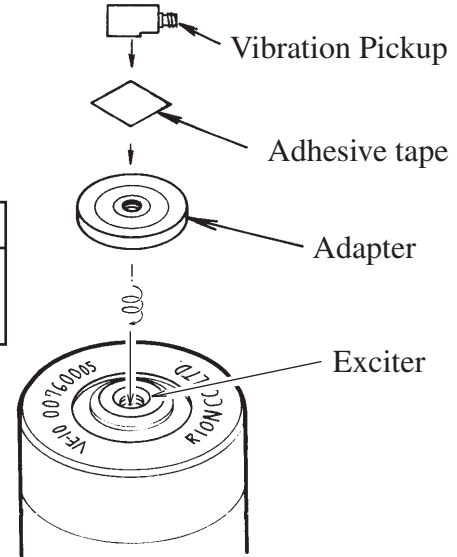



## Operation Mode

The VE-10 provides two operation modes. The mode can be changed by pressing the power/mode switch.

**Note**

Do not press the switch strongly with a sharp pointed object such as pointed tweezers.

### Auto-stop (pushes once)

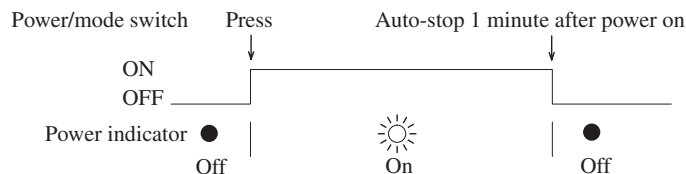

### Continuous operation (pushes twice within five seconds)

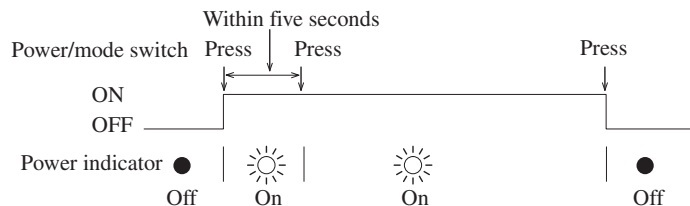

# Calibration

The VE-10 should be in the soft case when performing calibration. Also, do not give vibrations to the VE-10 especially when calibrating in velocity and displacement.

## Calibration of Vibration Measurement System

1. Set up the vibration meter (or vibration level meter) for  $10 \text{ m/s}^2$  (rms) acceleration,  $10 \text{ mm/s}$  (rms) velocity, or  $10 \text{ }\mu\text{m}$  (rms) displacement measurement.
2. Set the sensitivity of the vibration meter to the sensitivity of the vibration pickup in use.
3. Press once the power/mode switch. The power indicator lights up, and the VE-10 generates a sinusoidal vibration of  $10 \text{ m/s}^2$  (rms) in acceleration,  $10 \text{ mm/s}$  (rms) in velocity,  $10 \text{ }\mu\text{m}$  (rms) in displacement.
4. Five seconds after switching on the VE-10, check the meter indication. If the meter does not show the correct value, adjust the meter sensitivity.

---

## Sensitivity Check of Accelerometer

1. Set up the vibration meter (or vibration level meter) for  $10 \text{ m/s}^2$  (rms) acceleration measurement.
2. Set the sensitivity of the meter to the sensitivity of the accelerometer.
3. Press once the power/mode switch. The power indicator lights up.
4. Five seconds after switching on the VE-10, adjust the sensitivity control of the meter so that the meter indicates  $10 \text{ m/s}^2$  (rms).  
The reading of the sensitivity control shows the correct sensitivity of the accelerometer in  $\text{pC}/(10 \text{ m/s}^2)$ .

# Specifications

Frequency:	159.2 Hz		$\pm 1\%$ (-10 to +55°C)
Acceleration:	10 m/s <sup>2</sup> (rms)	14.14 m/s <sup>2</sup> (peak)	$\pm 3\%$ (+10 to +40°C) $\pm 5\%$ (-10 to +55°C)
Velocity:	10 mm/s (rms)	14.14 mm/s (peak)	$\pm 4\%$ (+10 to +40°C) $\pm 6\%$ (-10 to +55°C)
Displacement:	10 $\mu\text{m}$ (rms)	14.14 $\mu\text{m}$ (peak)	$\pm 5\%$ (+10 to +40°C) $\pm 7\%$ (-10 to +55°C)

---

Transverse amplitude:	5% or less of main axis amplitude
Maximum load:	70 g
Total harmonic distortion:	3% or less (20 to 60 g load) 5% or less (10 to 70 g load)
Overload detection:	Automatically stops operation for more than 100 g load
Operation mode:	Auto-stop (approx. 1 minute operation) and continuous operation
Battery:	IEC 6LR61 (9 V) alkaline battery
Battery life:	10 h or more for continuous operation, 600 times or more operations for auto-stop mode (with 70 g load)
Ambient conditions for operation:	-10 to +55°C      90%RH or less
Dimensions and weight:	approx. 51 (dia.) × 134 (H) mm, approx. 600 g

Supplied accessories:	Adapter	1
	M6 screw	1
	M6-UNF screw	1
	Soft case	1
	6LR61 alkaline battery	1
	Instruction manual	1
	Inspection certificate	1

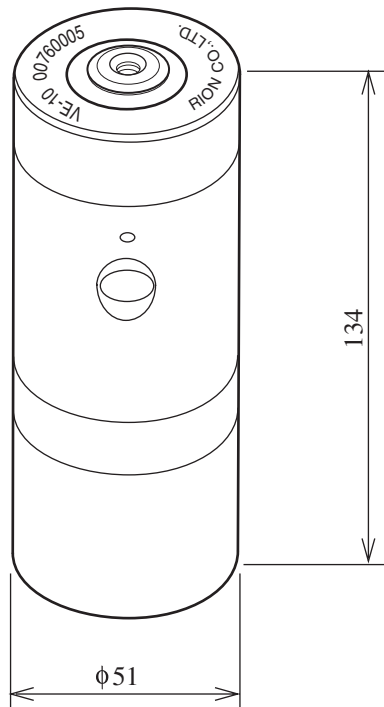

Unit: mm

Dimensional drawing of VE-10

